

*OPTIONAL CLAMPS

*TERMINAUX OPTIONNELS

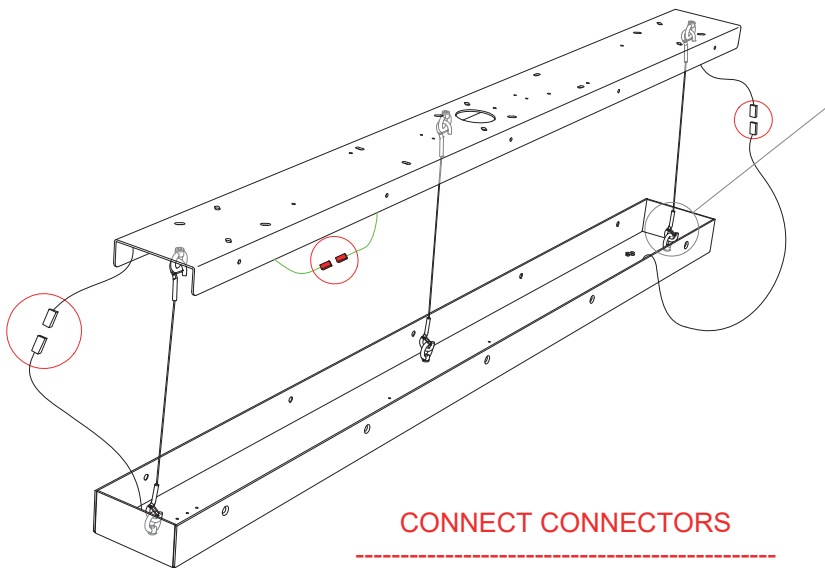

CONNECT CONNECTORS
CONNECTER LES CONNECTEURS

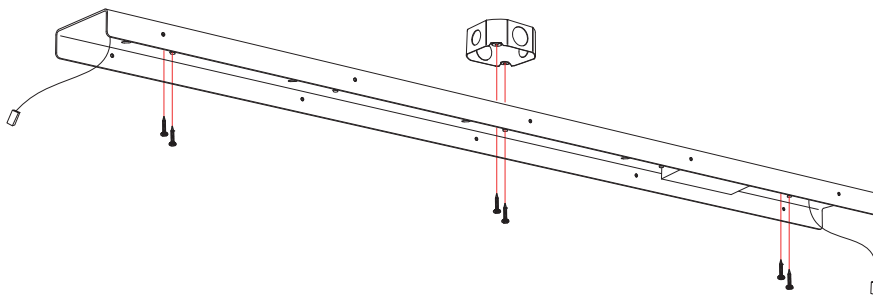
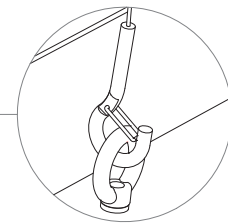

1. Fix the bracket to the ceiling.
 (use appropriate anchors depending on the type of wall).
 Fasten the hooks connected to the rosette to the eyebolts positioned on the bracket.

1. Fixez le support au plafond.
 (utilisez des ancrages appropriés selon le type de mur).
 Fixez les crochets reliés à la rosette aux boulons à oeil positionnés sur le support.

To inspect the electrical connections, remove the illuminated part from the mounting plate leaving it attached to the hooks.

Pour inspecter les connexions électriques, retirez la partie éclairée de la plaque de montage en la laissant attachée aux crochets.

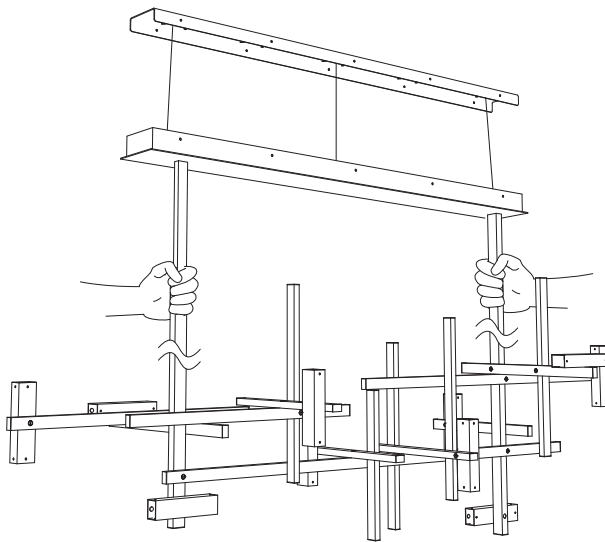

2. Hold the lamp carefully from the central beam and connect the wires cables following the driver instruction attached.

2. Tenez la lampe avec précaution du faisceau central et connectez les câbles électriques en suivant les instructions du driver jointes.

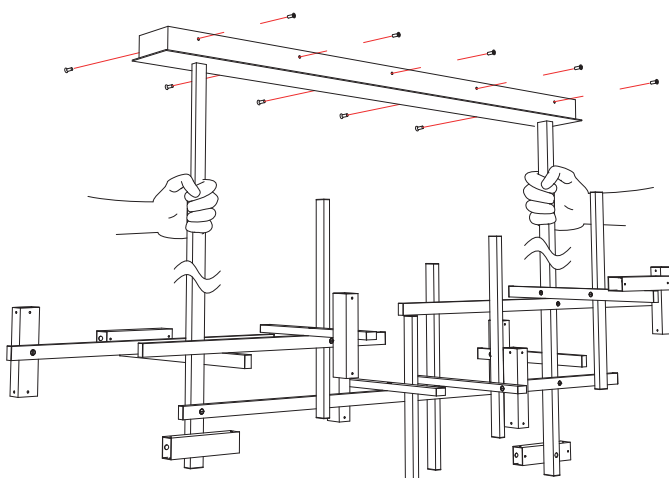

3. Fix the lamp to the bracket with the screws provided.

3. Fixez la lampe au support avec les vis fournies.

4. Fix the crystal diusers in the proper position following the instruction attached.

4. Fixez les diuseurs à cristal dans la bonne position en suivant les instructions jointes

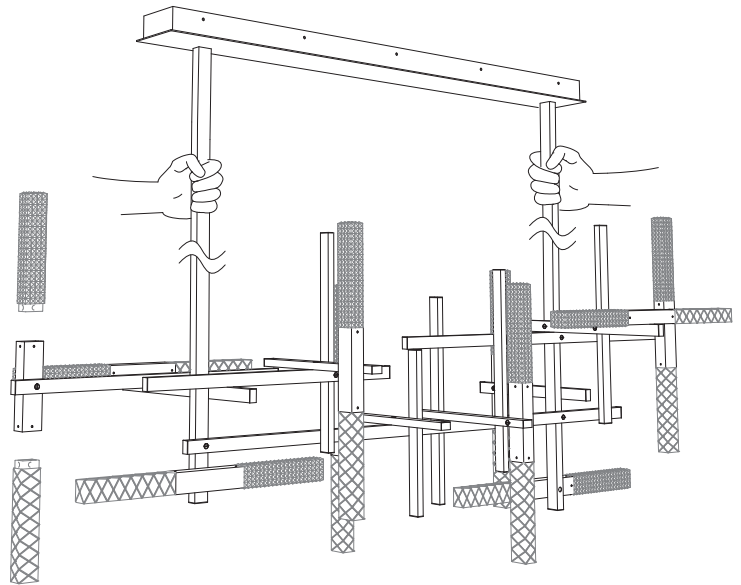

5. Some tubes of the structure may tilt after xing the diusers, make sure that all the lamp is in the correct conguration.

Straighten the tubes and nally tighten the screws with a at-blade screwdriver.

5. Certains tubes de la structure peuvent s'incliner après avoir xé les diuseurs, assurez-vous que toute la lampe est dans la bonne conguration. Redresser les tubes et enn serrer les vis avec un tournevis à lame plate.

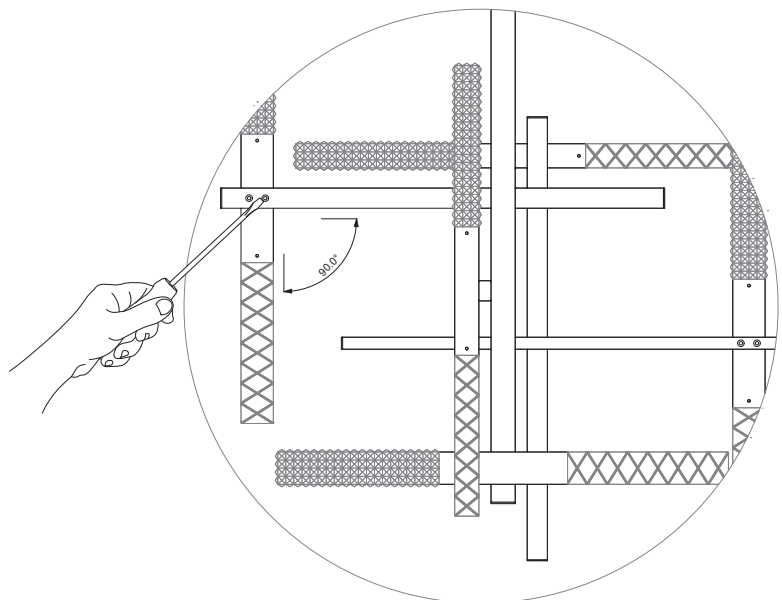



1. KIT



2. Inserire il diffusore di vetro nel suo scompartimento, applicando una leggera pressione sui lati.
Insert the glass diffuser into the proper space, applying a little pressure in the sides.



3. Stringere il grano sul lato sinistro con la chiave fornita.
Screw the grain on the left side with the provided Allen Key.



4. Stringere il grano sul lato destro.
Screw the grain on the right side.



5. Stringere il grano sul lato posteriore.
Screw the grain on the back.

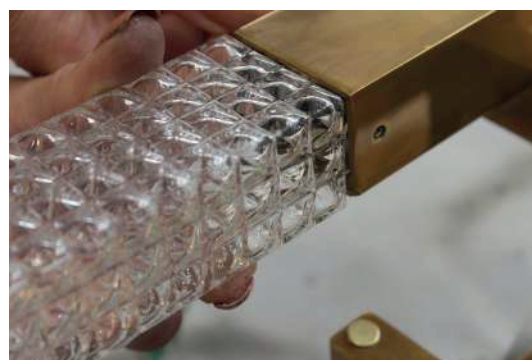

6. Verificare che il vetro sia fissato bene, dopodichè ripetere i cinque passaggi per tutti i vetri.
Check that the glass diffuser is well fastened, then repeat the five steps for all the glasses.

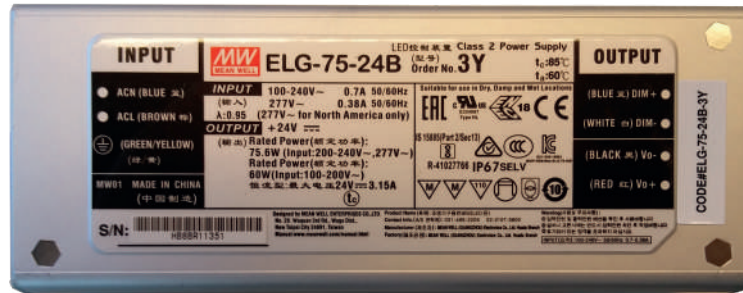

IS 15685 (Part 2/Sec13)
R-41027766
(for 12B/24B/36A/42A/48A only)

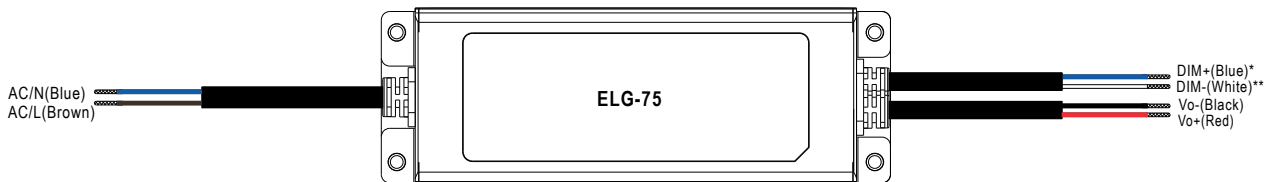

☒ **3 in 1 dimming function (for B/AB-Type)**

- Output constant current level can be adjusted by applying one of the three methodologies between DIM+ and DIM-: 0 ~ 10VDC, or 10V PWM signal or resistance.
- Direct connecting to LEDs is suggested. It is not suitable to be used with additional drivers.
- Dimming source current from power supply: 100μA (typ.)

☒ **Applying additive 0 ~ 10VDC**

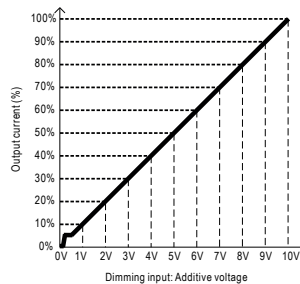
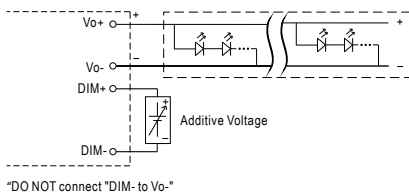

☒ **Applying additive 10V PWM signal (frequency range 100Hz ~ 3KHz):**

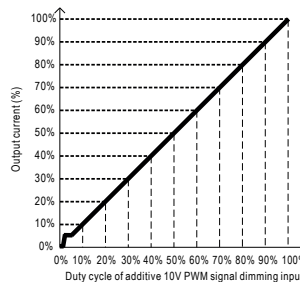
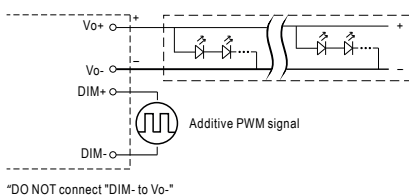

☒ **Applying additive resistance:**

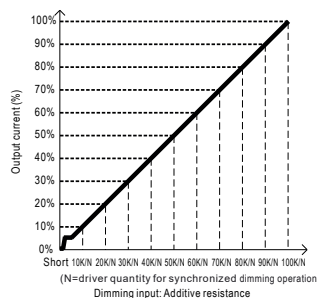
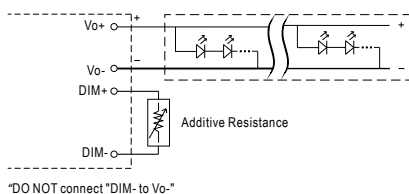

Note : 1. Min. dimming level is about 8% and the output current is not defined when 0% < I_{out} < 8%.
2. The output current could drop down to 0% when dimming input is about 0kΩ or 0Vdc, or 10V PWM signal with 0% duty cycle.

* DIM+ for B/AB-Type
DA+ for DA-Type
PROG+ for D2-Type
** DIM- for B/AB-Type
DA- for DA-Type
PROG- for D2-Type